



Triple Offset Butterfly Valve

Series 21



Foreword

FCC Butterfly Valve design eliminates rubbing action of the sealing elements during the entire 90-degree rotation. Direct line contact between the seal and disc seating surface is established only when closed position is reached.

Valve Model Numbering

Series	Rating	Trim Type	Temperature
21	1- 150	30- Triple Offset, Metal / Graphite Laminated Seal	1- Warm Service
	2- 300		2- Cryogenic
	3- 600		

Engineering Data

Table 1.1

Body Style	Lugged Wafer, Double Flanged Short
Design	API 609, ASME B16.34
Sizes, Pressure rating	3" to 36", ASME Class 150-600
Trim Type	Triple Offset
Flow Characteristics	Modified Equal Percentage (Inherent)
Seat Leakage	ANSI / FCI 70.2 / IEC 60534-4 Standard: Class IV - Class VI Optional: API 598
Flow Direction	Flow to Close (Standard) Bi-Directional on Request
NACE Conformance	NACE Conformance shall be Offered for Body and Disc material when required
Seal Style	Laminated Metal Seal
End Connection Styles	Standard Flanged RF as per ASME B16.5 Optional Flanged FF as per ASME B16.5
Face To Face	API 609

Features and Benefits

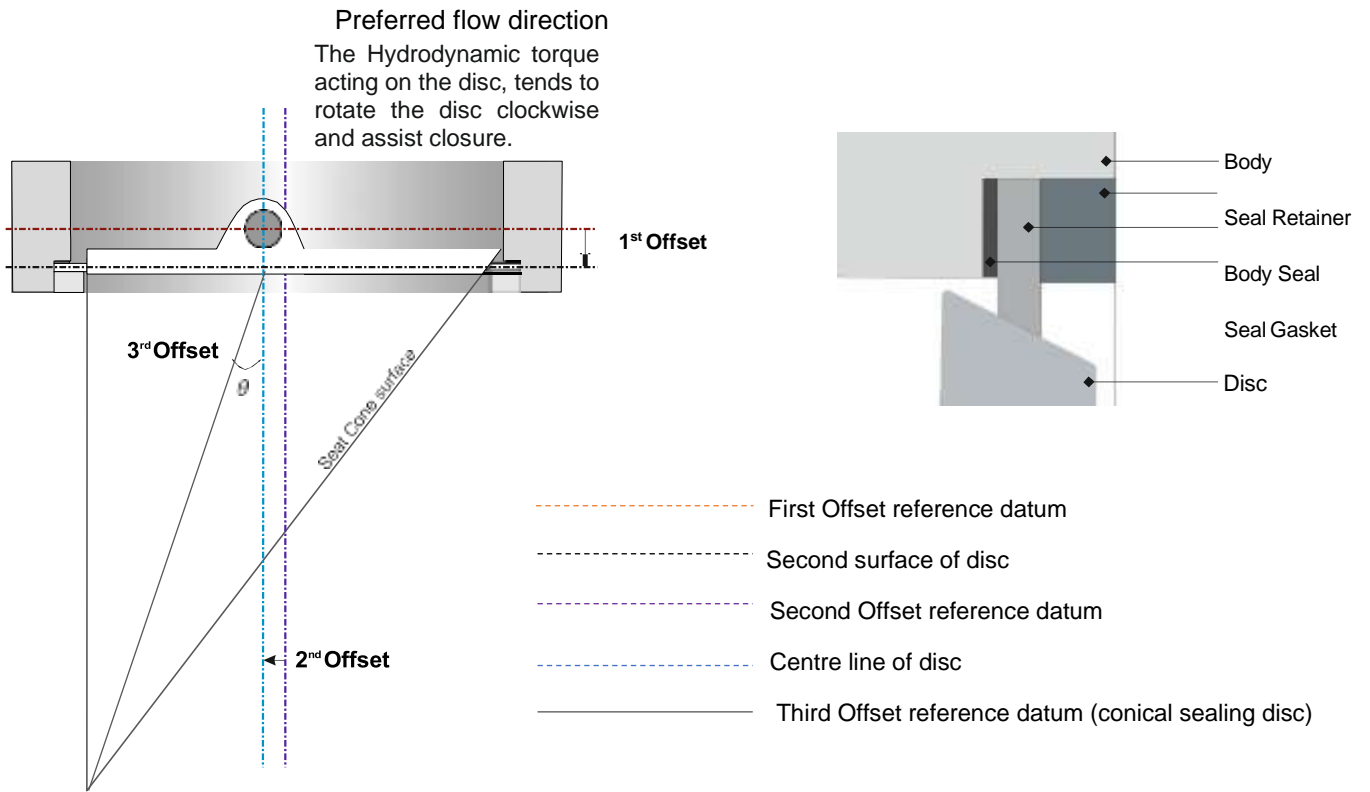

Triple Offset Lamination seal is developed as a combination of compressible & resilient materials such as Graphite or PTFE, sandwiched between layers of thin metal sheets.

While the metal sheets offer the strength and rigidity, Graphite/PTFE provide good sealing. Each individual layer performs an independent sealing and is unaffected by the damages to other layers.

The seal is suitable for a wide ranging temperature from cryogenic to very high temperatures (-190° C to 450° C)

Part List Description

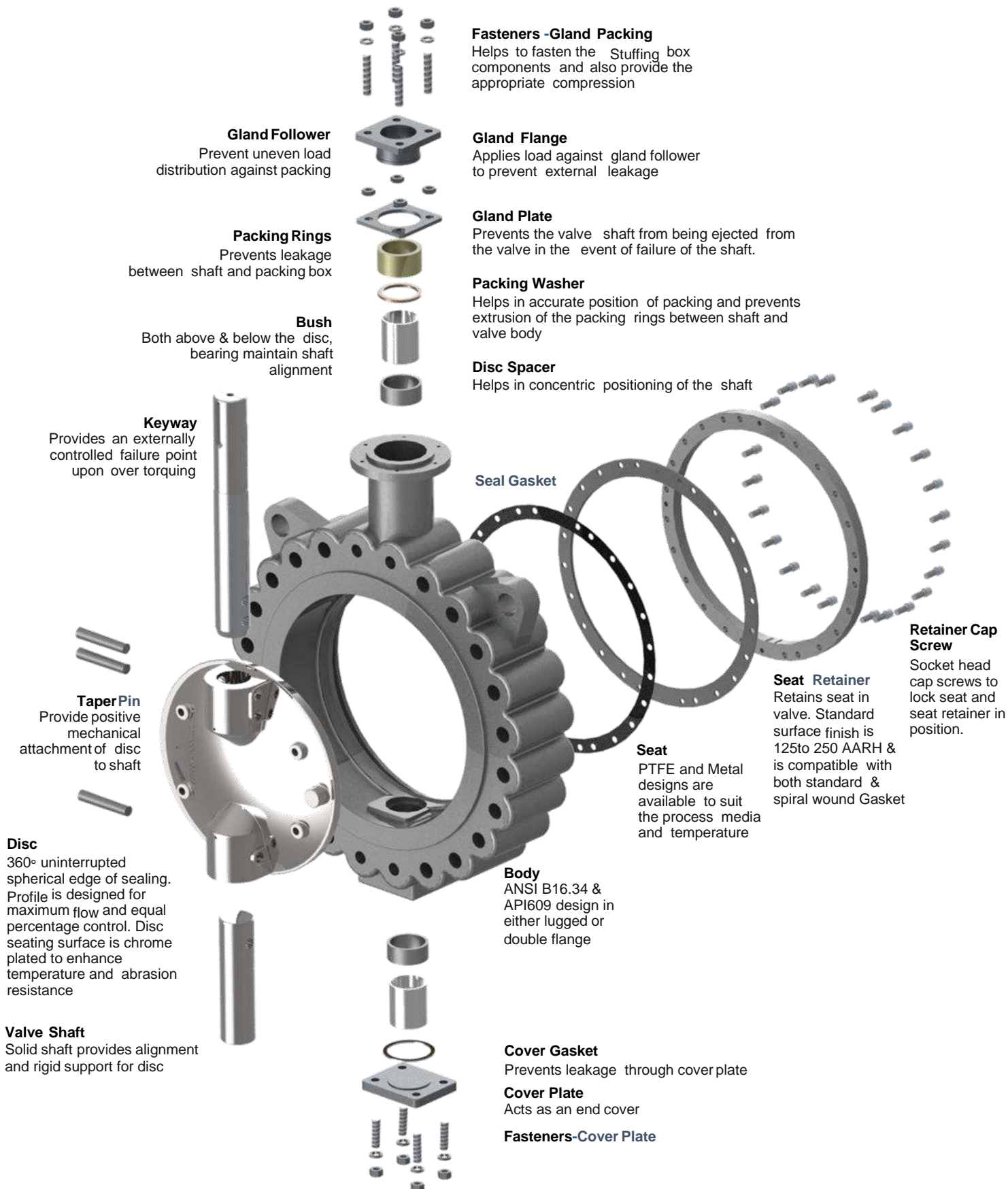

Material Of Construction

Table 2.1: Materials of Construction for Body, Seal arrangement & Disc assembly

Key No.	Description	Carbon Steel	Stainless steel	Duplex	Super Duplex	Al. Bronze	Monel
1.	Valve Body	WCB	CF8M	4A	6A	C95400	M35-1
2.	Disc	CF8M	CF8M	4A	6A	C95400	M35-1
3.	Drive shaft	17-4PH	17-4PH	S32760	S32760	Alloy K500	Alloy K 500
4.	Non-drive shaft	17-4PH	17-4PH	S32760	S32760	Alloy K500	Alloy K500
5.	Taper pin	17-4PH	17-4PH	Alloy 718	Alloy 718	Alloy 718	Alloy 718
6.	Seal Gasket	Graphite+ S31600		Graphite+ Alloy 625			
7.	Laminated Metal Seal	S31600+ Graphite		Alloy 625+ Graphite			
8.	Seal Retainer	S31600	S31600	S32760	S32760	Alloy 625	Alloy 625
9.	Retainer Cap Screws	S31600	S31600	S32760	S32760	Alloy 625	Alloy 625
10.	Disc Spacer	XM-19	XM-19	S32760	S32760	Alloy 625	Alloy 625

Table 2.2: Material of Construction for Packing Box, Cover Flange

Key No.	Description	Carbon steel
11.	Guide Bush	DU Bush
12.	Gland Flange	S31600
13.	Gland Follower	S31600
14.	Gland Plate	S31600
15.	Packing	PTFE
16.	Packing washer	Alloy 625
17.	Gland stud & nut	S31600
18.	Cover plate	S31600, S32760
19.	Cover Gasket	S31600 spiral wound graphite
20.	Cover stud & nut	S31600

Optional Variants

NACE MR-0175 / ISO 15156 & MR-0103 Conformance

Stellite on disc seating area

Alloy 718, XM-19 shaft based on valve torque

Stellite bush

Graphite packing

Alloy 625 Cover plate

Flow Coefficients

Table 3.1: ASME Class 150

Valve Size (in)	Degree of opening			
	10	60	70	90
3	3	103	135	159
4	5	150	210	288
6	40	588	845	989
8	86	969	1340	1532
10	143	1660	2464	2857
12	207	2248	3518	4222
14	215	2868	4392	5545
16	309	3771	6087	7679
18	402	4553	7604	9662
20	492	5893	9854	12804
24	716	8215	14305	19385
30	1112	12940	24128	34182
36	1625	18680	32023	43483

Note: 1. Triple offset Butterfly valve with standard disc

Note:2. Direction: Seat downstream flow

Table 3.2: ASME Class 300

Valve Size (in)	Degree of opening			
	10	60	70	90
3	3	98	128	154
4	5	143	200	279
6	40	548	737	822
8	84	948	1323	1507
10	134	1538	2316	2783
12	201	2217	3270	4034
14	190	2666	3836	4853
16	256	3652	5492	7510
18	344	4298	6827	8405
20	485	5587	8333	10335
24	678	7894	12442	15843
30	1064	12593	20420	27295

Note: 1. Triple offset Butterfly valve with standard disc

Note:2. Direction: Seat downstream flow

Table 3.3: ASME Class 600

Valve Size (in)	Degree of opening			
	10	60	70	90
3	3	93	122	146
4	5	135	190	265
6	32	539	738	821
8	77	940	1305	1488
10	104	1342	1769	1970
12	172	2095	2790	3350
14	169	2356	3204	4113
16	222	3193	4137	4849
18	321	4322	5887	7223
20	459	5655	8194	9975
24	565	7886	12194	15475
30	1000	12506	19635	26871

Note: 1. Triple offset Butterfly valve with standard disc

Note:2. Direction: Seat downstream flow

Valve Torque
Dynamic Torque

The Triple Offset Geometry results in Torque that tends to rotate the disc towards the seat and assists valve closure, as the fluid flows in the preferred direction (seat down-stream)

Combined effect of Geometry and the Hydrodynamic fluid pressure around the disc, results in a torque that increases steadily with increase in opening, reaches its peak at around 70-80 degree, and thereafter falls rapidly.

Neglect the dynamic torque values if used for ON/OFF applications.

Hydrodynamic torque characteristics is represented in **chart – 1** below.

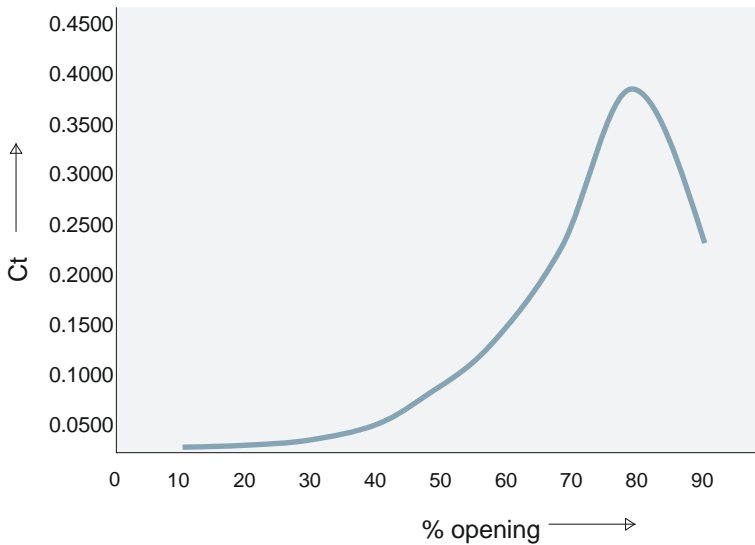

Chart-1: Ct Vs % opening

Table 4: Co-efficient of dynamic torque Ct

Percentage of Opening	Coefficient of dynamic torque
10	0.0036
20	0.0073
30	0.0226
40	0.0452
50	0.0839
60	0.1372
70	0.2292
80	0.376
90	0.2228

Hydrodynamic torque can be calculated using the formula

$$T_d = (C_t \times D) \times \Delta P$$

Where, T_d – Dynamic Torque in lbs inch

C_t – Torque Coefficient Factor

D – Disc Diameter in inch

ΔP – Pressure Drop in psi(g)

Break Torque

MAST – Maximum Allowable Shaft Torque. 17-4 PH is the standard shaft material

The MAST value corresponds to 17-4 PH, For other materials multiply this value with the factors given in the table below.

Table 5.1

Materials	Nitronic 50	S32760	Monel K500	Inconel 718
Factor	0.7	0.82	0.97	1.9

Under certain conditions, hydrodynamic torque can meet or exceed the Break Torques.

When designing valve systems, hydrodynamic torque must be considered to ensure correct selection of actuator.

Table 5.2: Break Torque – ASME Class 150

Conversion: 1 lbs.inch =0.1129Nm

Valve Size (in)	Stem Dia (inch)	Metal Seal (lbs.in)				MAST lbs.in
		Differential Pressure (bar)				
		5	10	15	20	
3	0.625	712	784	855	927	2903
4	0.75	878	1010	1141	1273	5016
6	0.75	1368	1685	2002	2320	5016
8	1	2487	3152	3817	4481	11889
10	1	3629	4629	5629	6629	11889
12	1.25	5540	7227	8914	10600	23221
14	1.5	7578	10080	12583	15086	40126
16	1.5	9957	13282	16608	19933	40126
18	1.75	13118	17812	22505	27199	63718
20	2	16410	22642	28874	35106	95113
24	2.25	24653	34568	44483	54398	135425
30	3	44109	64257	84405	104554	321007
36	3.5	63148	93975	124803	155630	509748

Table 5.3: Break Torque – ASME Class 300

Conversion: 1 lbs.inch =0.1129Nm

Valve Size (in)	Stem Dia (inch)	Metal Seal (lbs.in)				MAST lbs.in
		Differential Pressure (bar)				
		20	30	40	50	
3	0.625	988	1162	1336	1510	2903
4	0.75	1252	1505	1759	2012	5016
6	1	2402	3050	3699	4347	11889
8	1.25	4565	5909	7253	8597	23221
10	1.25	6741	8769	10797	12825	23221
12	1.5	10720	14125	17531	20936	40126
14	2	15528	20698	25869	31040	95113
16	2	19845	26395	32946	39497	95113
18	2.25	27445	36899	46354	55809	135425
20	2.75	35702	48380	61059	73737	247257
24	3	55800	76246	96695	117142	321007
30	3.5	106389	147546	188706	229865	509748

Table 5.4: Break Torque – ASME Class 600

Conversion: 1 lbs.inch =0.1129Nm

Valve Size (in)	Stem Dia (inch)	Metal Seal (lbs.in)				MAST lbs.in
		Differential Pressure (bar)				
		50	65	80	100	
3	0.625	1593	1879	2164	2546	2903
4	0.75	2152	2573	2995	3557	5016
6	1	4684	5757	6831	8262	11889
8	1.25	9207	11406	13605	16537	23221
10	1.75	13855	17172	20490	24913	63718
12	2	22412	27929	33447	40804	95113
14	2.25	32905	41204	49503	60568	135425
16	2.5	42012	52559	63107	77170	185768
18	2.5	58987	74088	89190	109326	185768
20	2.75	77508	97639	117772	144615	247257
24	3.25	122632	154931	187234	230303	408133
30	3.5	238755	303157	367565	453438	509748

Dimensions and Weights

Table 6.1: ASME Class 150

Valve Size (in)	Dimensions (mm)								Actuator Mounting Flange Type ISO 5211	Weight (Kg)	
	LW	DF	B	C	D	Ø E	Ø F	Ø S		LW	DF
	A									LW	DF
3	48	114	130	160	75	66	212	5/8"	F05	8	27
4	54	127	140	170	90	91	230	3/4"	F07	16	31
6	57	140	170	200	90	135	280	3/4"	F07	20	39
8	64	152	205	235	110	188	344	1"	F10	34	64
10	71	165	245	280	110	236	408	1"	F12	55	89
12	81	178	275	310	120	284	483	1-1/4"	F14	80	129
14	92	190	310	360	145	328	535	1-1/2"	F14	105	163
16	102	216	340	400	145	366	598	1-1/2"	F16	142	210
18	114	222	365	425	165	414	637	1-3/4"	F16	180	240
20	127	229	405	465	165	465	700	2"	F25	235	285
24	154	267	460	520	180	561	817	2-1/4"	F25	349	450
30	165	318	605	680	210	711	988	3"	F30	583	725

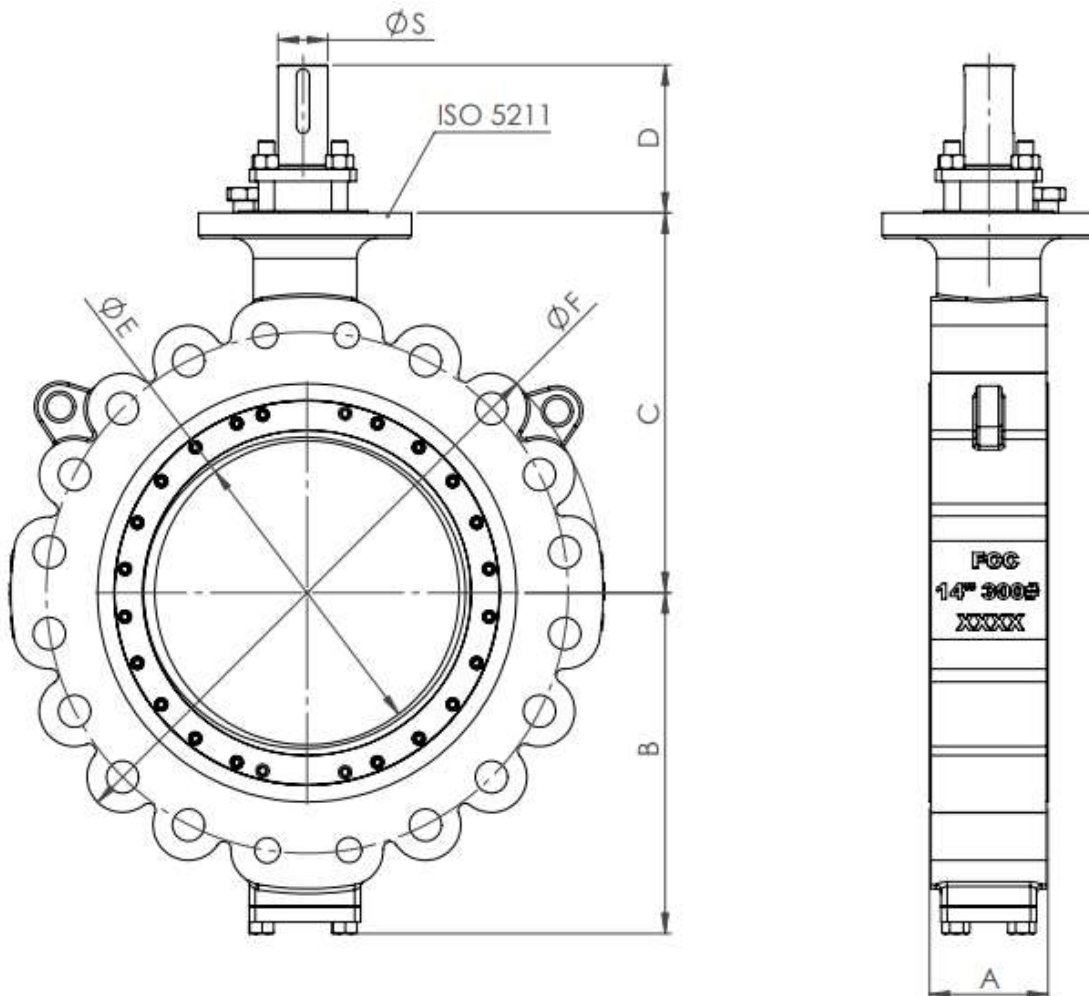

TRIPLE OFFSET BUTTERFLY VALVE SERIES 21

Table 6.2: ASME Class 300

Valve Size (in)	Dimensions (mm)								Actuator Mounting Flange Type ISO 5211	Weight (Kg)	
	LW	DF	B	C	D	Ø E	Ø F	Ø S		LW	DF
	A										
3	48	114	130	160	75	66	212	5/8"	F07	14	26
4	54	127	155	185	90	91	254	3/4"	F07	20	39
6	59	140	190	220	110	135	319	1"	F10	34	63
8	73	152	260	270	120	188	384	1-1/4"	F12	57	98
10	83	165	270	310	120	236	445	1-1/4"	F14	85	130
12	92	178	310	350	145	284	524	1-1/2"	F16	123	180
14	117	190	340	390	165	328	584	2"	F16	207	256
16	133	216	370	420	165	366	650	2"	F25	269	329
18	149	222	405	480	180	414	712	2-1/4"	F25	357	400
20	159	229	440	515	210	465	777	2-3/4"	F30	416	505
24	181	267	515	600	210	561	918	3"	F30	635	753
30	241	318	615	700	210	711	1096	3-1/2"	F35	1103	1125

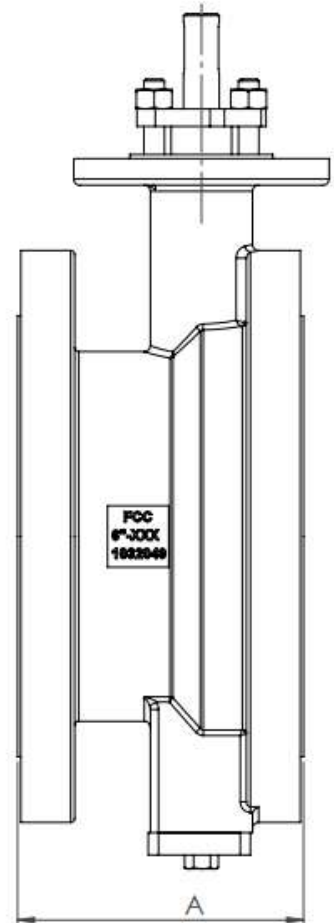
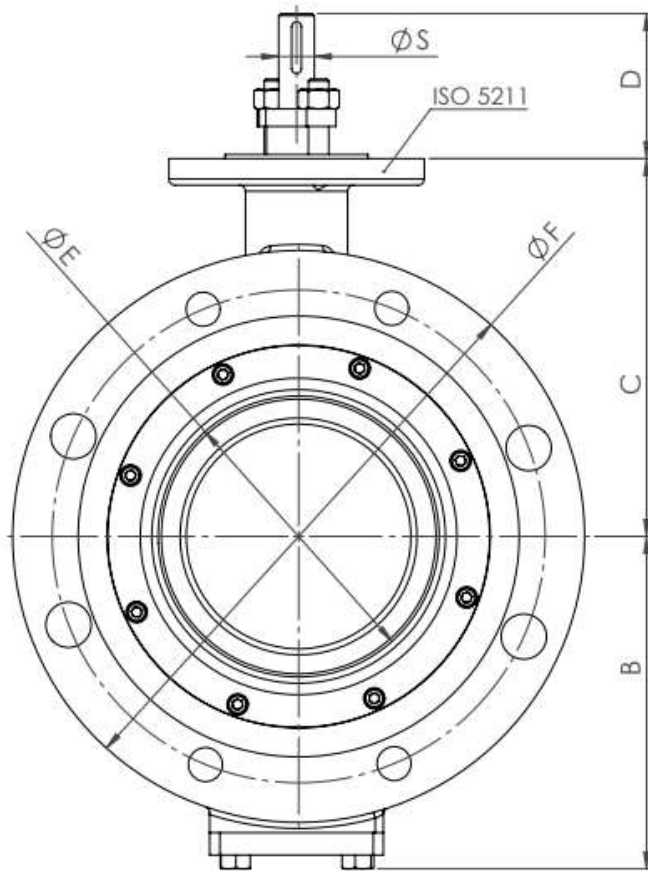

TRIPLE OFFSET BUTTERFLY VALVE
SERIES 21

Table 6.3: ASME Class 600

Valve Size (in)	Dimensions (mm)								Actuator Mounting Flange Type ISO 5211	Weight (Kg)	
	LW	DF	B	C	D	Ø E	Ø F	Ø S		LW	DF
	A										
3	54	180	130	165	75	66	210	5/8"	F10	15	30
4	64	190	165	210	90	91	275	3/4"	F10	28	52
6	78	210	215	250	110	135	355	1"	F12	58	101
8	102	230	255	290	120	188	422	1-1/4"	F14	99	173
10	117	250	305	350	165	236	510	1-3/4"	F16	178	270
12	140	270	335	380	165	284	560	2"	F25	223	310
14	155	290	355	410	180	328	605	2-1/4"	F25	280	370
16	178	310	420	500	200	366	688	2-1/2"	F30	425	550
18	200	330	440	520	200	414	745	2-1/2"	F30	515	660
20	216	350	470	550	210	465	815	2-3/4"	F35	652	780
24	232	390	535	620	210	561	942	3-1/4"	F35	880	1080
30	318	450	625	710	210	711	1132	3-1/2"	F40	1540	1750

End Connections Bolting Details (LW)

Table 7.1: ASME Class 150

Valve Size (in)	Drilled Holes					Tapped Holes				
	Stud Size	Length (in)	No of Studs	Nut Size	No of Nuts	Stud Size	Length (in)	No of Studs	Nut Size	No of Nuts
3	5/8- 11 UNC	6	4	5/8- 11 UNC	8	-	-	-	-	-
4	5/8- 11 UNC	6.25	8	5/8- 11 UNC	16	-	-	-	-	-
6	3/4- 10 UNC	6.75	8	3/4- 10 UNC	16	-	-	-	-	-
8	3/4- 10 UNC	7.25	8	3/4- 10 UNC	16	-	-	-	-	-
10	7/8- 9 UNC	8	12	7/8- 9 UNC	24	-	-	-	-	-
12	7/8- 9 UNC	8.5	12	7/8- 9 UNC	24	-	-	-	-	-
14	1-8 UN	9.5	12	1-8 UN	24	-	-	-	-	-
16	1-8 UN	10	16	1-8 UN	32	-	-	-	-	-
18	1-1/8- 8 UN	11	16	1-1/8- 8 UN	32	-	-	-	-	-
20	1-1/8- 8 UN	11.75	16	1-1/8- 8 UN	32	1-1/8- 8 UN	4.5	8	1-1/8- 8 UN	8
24	1-1/4- 8 UN	13.5	16	1-1/4- 8 UN	32	1-1/4- 8 UN	5	8	1-1/4- 8 UN	8
30	1-1/4- 8 UN	16.25	24	1-1/4- 8 UN	48	1-1/4- 8 UN	6.25	8	1-1/4- 8 UN	8

Table 7.2: ASME Class 300

Valve Size (in)	Drilled Holes					Tapped Holes				
	Stud Size	Length (in)	No of Studs	Nut Size	No of Nuts	Stud Size	Length (in)	No of Studs	Nut Size	No of Nuts
3	3/4- 10 UNC	6.5	8	3/4- 10 UNC	16	-	-	-	-	-
4	3/4- 10 UNC	7	8	3/4- 10 UNC	16	-	-	-	-	-
6	3/4- 10 UNC	7.75	12	3/4-10 UNC	24	-	-	-	-	-
8	7/8- 9 UNC	9	12	7/8- 9 UNC	24	-	-	-	-	-
10	1-8 UN	10	12	1-8 UN	24	1-8 UN	4.5	8	1-8 UN	8
12	1-1/8- 8 UN	11	16	1-1/8- 8 UN	32	1-1/8-8 UN	4.75	8	1-1/8- 8 UN	8
14	1-1/8- 8 UN	12.25	16	1-1/8- 8 UN	32	1-1/8-8 UN	5	8	1-1/8- 8 UN	8
16	1-1/4- 8 UN	13.25	16	1-1/4- 8 UN	32	1-1/4- 8 UN	5.25	8	1-1/4- 8 UN	8
18	1-1/4- 8 UN	14.25	20	1-1/4- 8 UN	40	1-1/4- 8 UN	5.5	8	1-1/4- 8 UN	8
20	1-1/4- 8 UN	15	20	1-1/4- 8 UN	40	1-1/4- 8 UN	5.75	8	1-1/4- 8 UN	8
24	1-1/2- 8 UN	16.75	20	1-1/2- 8 UN	40	1-1/2- 8 UN	6.5	8	1-1/2- 8 UN	8
30	1-3/4- 8 UN	21.75	24	1-3/4- 8 UN	48	1-3/4- 8 UN	8	8	1-3/4- 8 UN	8

Table 7.3: ASME Class 600

Valve Size (in)	Drilled Holes					Tapped Holes				
	Stud Size	Length (in)	No of Studs	Nut Size	No of Nuts	Stud Size	Length (in)	No of Studs	Nut Size	No of Nuts
3	3/4- 10 UNC	7.25	8	3/4- 10 UNC	16	-	-	-	-	-
4	7/8- 9 UNC	8.5	8	7/8- 9 UNC	16	-	-	-	-	-
6	1-8 UN	10	12	1-8 UN	24	-	-	-	-	-
8	1-1/8- 8 UN	11.75	12	1-1/8- 8UN	24	-	-	-	-	-
10	1-1/4- 8 UN	13.25	12	1-1/4- 8 UN	24	1-1/4-8 UN	5.75	8	1-1/4- 8 UN	8
12	1-1/4-8 UN	14.5	16	1-1/4- 8 UN	32	1-1/4-8 UN	5.75	8	1-1/4- 8 UN	8
14	1-3/8- 8 UN	15.5	16	1-3/8- 8 UN	32	1-3/8-8 UN	6.25	8	1-3/8- 8 UN	8
16	1-1/2- 8 UN	17.25	16	1-1/2- 8 UN	32	1-1/2- 8 UN	6.75	8	1-1/2- 8 UN	8
18	1-5/8- 8 UN	18.75	16	1-5/8- 8 UN	32	1-5/8- 8 UN	7.25	8	1-5/8- 8 UN	8
20	1-5/8- 8 UN	20	20	1-5/8- 8 UN	40	1-5/8- 8 UN	7.5	8	1-5/8- 8 UN	8
24	1-7/8- 8 UN	22.25	20	1-7/8- 8 UN	40	1-7/8- 8 UN	8.5	8	1-7/8- 8 UN	8
30	2- 8 UN	27.25	24	2- 8 UN	48	2- 8 UN	9.5	8	2- 8 UN	8

End Connection Bolting Details (DF)

Table 8.1: ASME Class 150

Valve Size (in)	Drilled Holes					Tapped Holes				
	Stud Size	Length (in)	No of Studs	Nut Size	No of Nuts	Stud Size	Length (in)	No of Studs	Nut Size	No of Nuts
3	5/8- 11 UNC	4	8	5/8- 11 UNC	16	-	-	-	-	-
4	5/8- 11 UNC	4	8	5/8- 11 UNC	16	5/8-11 UNC	2.75	8	5/8- 11 UNC	8
6	3/4- 10 UNC	4.25	8	3/4- 10 UNC	16	3/4-10 UNC	3	8	3/4- 10 UNC	8
8	3/4- 10 UNC	4.5	8	3/4- 10 UNC	16	3/4-10 UNC	3.25	8	3/4- 10 UNC	8
10	7/8- 9 UNC	5	16	7/8- 9 UNC	32	7/8- 9 UNC	3.5	8	7/8- 9 UNC	8
12	7/8- 9 UNC	5	16	7/8- 9 UNC	32	7/8-9 UNC	3.5	8	7/8- 9 UNC	8
14	1-8 UN	5.75	16	1-8 UN	32	1-8 UN	4	8	1-8 UN	8
16	1-8 UN	5.75	24	1-8 UN	48	1-8 UN	4	8	1-8 UN	8
18	1-1/8- 8 UN	6.25	24	1-1/8- 8 UN	48	1-1/8-8 UN	4.5	8	1-1/8- 8 UN	8
20	1-1/8- 8 UN	6.25	32	1-1/8- 8 UN	64	1-1/8- 8 UN	4.5	8	1-1/8- 8 UN	8
24	1-1/4- 8 UN	7.25	32	1-1/4- 8 UN	64	1-1/4- 8 UN	5	8	1-1/4- 8 UN	8
30	1-1/4- 8 UN	9.75	48	1-1/4- 8 UN	96	1-1/4- 8 UN	6.25	8	1-1/4- 8 UN	8

**TRIPLE OFFSET BUTTERFLY VALVE
SERIES 21**

Table 8.2: ASME Class 300

Valve Size (in)	Drilled Holes					Tapped Holes				
	Stud Size	Length (in)	No of Studs	Nut Size	No of Nuts	Stud Size	Length (in)	No of Studs	Nut Size	No of Nuts
3	3/4- 10 UNC	4.5	8	3/4- 10 UNC	16	3/4-10 UNC	3.25	8	3/4- 10 UNC	8
4	3/4- 10 UNC	4.75	8	3/4- 10 UNC	16	3/4-10 UNC	3.25	8	3/4- 10 UNC	8
6	3/4- 10 UNC	5.25	16	3/4-10 UNC	32	3/4-10 UNC	3.5	8	3/4- 10 UNC	8
8	7/8- 9 UNC	5.75	16	7/8- 9 UNC	32	7/8- 9 UNC	4	8	7/8- 9 UNC	8
10	1-8 UN	6.75	24	1-8 UN	48	1-8 UN	4.5	8	1-8 UN	8
12	1-1/8- 8 UN	7.25	24	1-1/8- 8 UN	48	1-1/8-8 UN	4.75	8	1-1/8- 8 UN	8
14	1-1/8- 8 UN	7.5	32	1-1/8- 8 UN	64	1-1/8-8 UN	5	8	1-1/8- 8 UN	8
16	1-1/4- 8 UN	8	32	1-1/4- 8 UN	64	1-1/4- 8 UN	5.25	8	1-1/4- 8 UN	8
18	1-1/4- 8 UN	8.25	40	1-1/4- 8 UN	80	1-1/4- 8 UN	5.5	8	1-1/4- 8 UN	8
20	1-1/4- 8 UN	8.5	40	1-1/4- 8 UN	80	1-1/4- 8 UN	5.75	8	1-1/4- 8 UN	8
24	1-1/2- 8 UN	9.5	40	1-1/2- 8 UN	80	1-1/2- 8 UN	6.5	8	1-1/2- 8 UN	8
30	1-3/4- 8 UN	12.25	48	1-3/4- 8 UN	96	1-3/4- 8 UN	8	8	1-3/4- 8 UN	8

Table 8.3: ASME Class 600

Valve Size (in)	Drilled Holes					Tapped Holes				
	Stud Size	Length (in)	No of Studs	Nut Size	No of Nuts	Stud Size	Length (in)	No of Studs	Nut Size	No of Nuts
3	3/4- 10 UNC	5	8	3/4- 10 UNC	16	3/4-10 UNC	3.25	8	3/4- 10 UNC	8
4	7/8- 9 UNC	5.75	8	7/8- 9 UNC	16	7/8- 9 UNC	4	8	7/8- 9 UNC	8
6	1-8 UN	6.75	16	1-8 UN	32	1-8 UN	4.5	8	1-8 UN	8
8	1-1/8- 8 UN	7.75	16	1-1/8- 8UN	32	1-1/8-8 UN	5	8	1-1/4- 8 UN	8
10	1-1/4- 8 UN	8.5	24	1-1/4- 8 UN	48	1-1/4-8 UN	5.75	8	1-1/4- 8 UN	8
12	1-1/4-8 UN	8.75	32	1-1/4- 8 UN	64	1-1/4-8 UN	5.75	8	1-1/4- 8 UN	8
14	1-3/8- 8 UN	9.25	32	1-3/8- 8 UN	64	1-3/8-8 UN	6.25	8	1-3/8- 8 UN	8
16	1-1/2- 8 UN	10	32	1-1/2- 8 UN	64	1-1/2- 8 UN	6.75	8	1-1/2- 8 UN	8
18	1-5/8- 8 UN	10.75	32	1-5/8- 8 UN	64	1-5/8- 8 UN	7.25	8	1-5/8- 8 UN	8
20	1-5/8- 8 UN	11.5	40	1-5/8- 8 UN	80	1-5/8- 8 UN	7.5	8	1-5/8- 8 UN	8
24	1-7/8- 8 UN	13	40	1-7/8- 8 UN	80	1-7/8- 8 UN	8.5	8	1-7/8- 8 UN	8
30	2- 8 UN	14.5	48	2- 8 UN	96	2- 8 UN	9.5	8	2- 8 UN	8



Flow Control Commune
9 Multi Industrial Estate, Gerugambakkam, Chennai 600122 India. Website: www.fccommune.com